

TOP

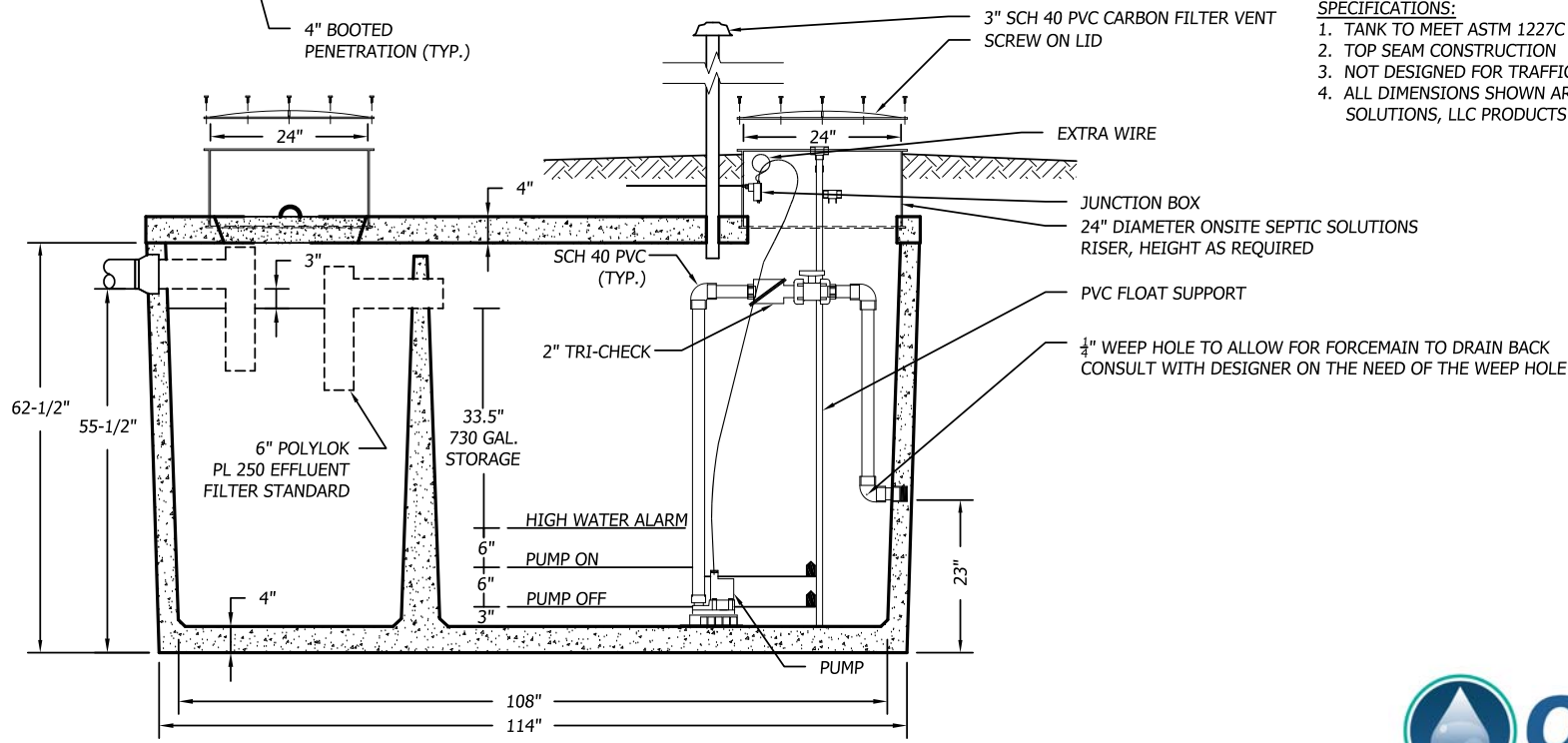

SECTION

NOTES:

1. FOR PUMP SPECIFICATIONS REFER TO PUMP DESIGN BRIEF.
2. THE CONTRACTOR AND SUPPLIER SHALL COORDINATE POWER REQUIREMENTS PRIOR TO ORDERING OF THE PUMP STATION.
3. PER ONSITE SEPTIC SOLUTIONS, LLC (SUPPLIER), THE TOP OF THIS TANK SHALL BE BURIED NO DEEPER THAN 3 FEET BELOW FINISHED GRADE. IF A DEEPER BURIAL DEPTH IS NEEDED SEE SUPPLIER FOR SIMILAR TANKS THAT CAN BE BURIED DEEPER THAN 3 FEET.
4. REFER TO THE PUMP STATION DESIGN BRIEF OR CONSULT THE DESIGNER ON THE NEED FOR A WEEP HOLE OR NOT.

SPECIFICATIONS:

1. TANK TO MEET ASTM 1227C REQUIREMENTS
2. TOP SEAM CONSTRUCTION
3. NOT DESIGNED FOR TRAFFIC AREAS
4. ALL DIMENSIONS SHOWN ARE PER ONSITE SEPTIC SOLUTIONS, LLC PRODUCTS 2017.

1,500 GALLON TOP SEAM PRECAST CONCRETE SMART STATION

1/2" = 1'-0"



BUSINESS PARK AT CAMBRIDGE
 CAMBRIDGE, VT. 05444
 paul@onsitesepanticsolutions.biz
 TEL. 802-644-5500