

PLAN

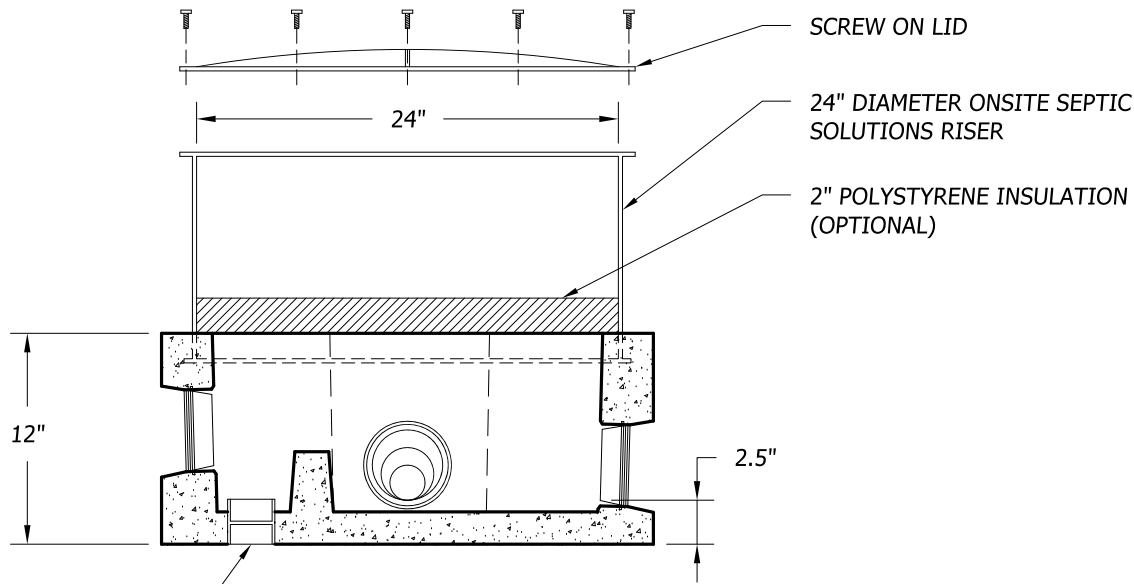

SECTION

NOTES:

1. THE DISTRIBUTION BOX SHOULD BE CHECKED FOR LEVEL ANNUALLY AND ADJUSTED AS NEEDED.

SPECIFICATIONS:

1. NOT DESIGNED FOR TRAFFIC AREAS
2. CONCRETE MINIMUM STRENGTH 5000 PSI @ 28 DAYS
3. 4" LOW PRESSURE PIPE SEALS
4. ONSITE SEPTIC SOLUTIONS RISERS ADJUSTABLE TO GRADE
5. CONCRETE = .07 YARDS = 280 LBS.
6. ALL DIMENSIONS SHOW ARE PER ONSITE SEPTIC SOLUTIONS, LLC PRODUCTS 2017.

2" SCH 40 COUPLING TO CONNECT TO FORCEMAIN

SCREW ON LID

24" DIAMETER ONSITE SEPTIC SOLUTIONS RISER

2" POLYSTYRENE INSULATION (OPTIONAL)

2.5"

12"

SECTION

5 OUTLET DISTRIBUTION BOX WITH FORCEMAIN

1"=1'-0"



BUSINESS PARK AT CAMBRIDGE
CAMBRIDGE, VT. 05444
paul@onsitesepoticsolutions.biz
TEL. 802-644-5500